

WIRE CABLE TRAYS

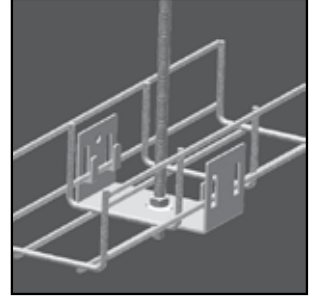

WIRE CABLE TRAYS

VFUL		
VFUL35	Wire cable tray	3-64
VFUL60	Wire cable tray	3-65
VFU		
VFU35	Wire cable tray for heavy duty	3-66
VFU60	Wire cable tray for heavy duty	3-67
VFU85	Wire cable tray for heavy duty	3-68
VFU110	Wire cable tray for heavy duty	3-69
GVFUL		
GVFUL	G-shaped wire cable tray	3-69
COVER		
D	Universal cover	3-70
COVER CLAMPS		
DCLVF	Cover clamp clips	3-70
DCLVF35	Cover clamp clips	3-71
ACCESSORIES		
VFO	Suspension piece for VFU(L)	3-71
VFOCL	Snap-in suspension for VFU(L)	3-71
VFM	Wall bracket for VFU(L)	3-72
VFMM	Wall and mounting bracket for VFU(L)	3-72
VFMM35	Wall and mounting bracket for VFU(L)	3-72
VFCL	Fixing clips for VFU(L)	3-73
VFCB	Central suspension bracket	3-73
OBG	Upper bracket	3-74
OBGVF	Open C-suspension bracket for VFU(L)	3-74
BGVF	External suspension bracket for VFU(L)	3-75
VFVLB	Floor bracket for VFU(L)	3-75
ZCL	Z-support clippable	3-76
MPVFCL	Profile for VFU(L)	3-76
COMEGACLU170	Open suspension bracket universal	3-77
COMEGACLU290	Open suspension bracket universal	3-78
LOMEGACLU150	Wall bracket universal	3-79
VMB	Floor and wall bracket	3-80
SLOS	Division plate free	3-80
VFSLOSCL	Clips for fixing SLOS to VFU(L)	3-81
MOUNTING PLATES		
VFK	Joining clamp	3-81
VFKG30	Joining clamp for VFU(L)	3-81
VFKK25	Joining clamp for VFU(L)	3-82
VFKS	Support joiner for VFU(L)	3-82
KPVF	Snap-on joiner for VFU(L)	3-83
KPVFL35	Snap quick-joiner for VFU(L)35	3-83
V35.200	Joining plate	3-83
TOOLS		
VFKNIP	Bolt cutter	3-84
TECHNICAL INFORMATION		3-85

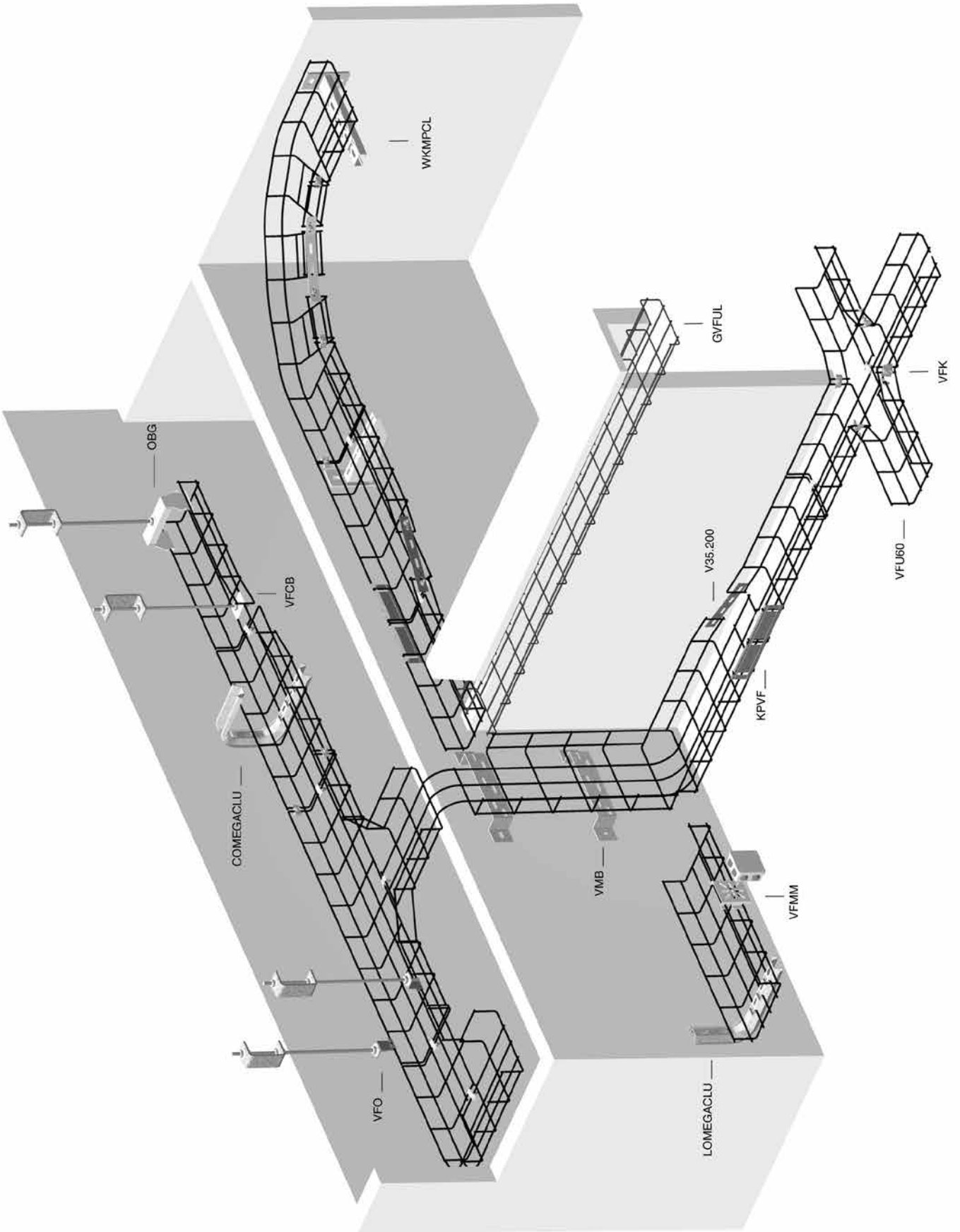

VFUL35

Wire cable tray

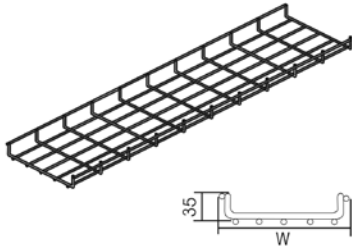

Screen: 50 x 100 mm
 Cross-wire: Ø 3.50 mm
 Lengthwise wire: Ø 4.50 mm

Standard finish	Pre-galvanised
Optional finish HD	Hot-dip galvanised
Optional finish PE	Coating

HD	Reference	↑ mm	↔ mm	↔ mm	↔ mm	kg/m	⊠	Stock	Unit
HD	VFUL30.065	30	65		3000	0.530	15	✓	m
HD	VFUL35.100	35	95		3000	0.570	30	✓	m
HD	VFUL35.150	35	146		3000	0.830	30	✓	m
HD	VFUL35.200	35	196		3000	0.870	30	✓	m
HD	VFUL35.250	35	245		3000	1.030	30	✓	m
HD	VFUL35.350	35	345		3000	1.330	30	✓	m

Fix with:									
HD	KPVFL35	45	248	-	-	0.100	30	✓	piece
HD	VFK	-	-	-	-	0.020	100	✓	piece

LOAD DIAGRAM

This diagram illustrates the permissible uniformly distributed loads applied to multiple supports. They comply with IEC 61537 with connection to 1/5 of the span and the end span = 0,8x the span. When the joint is situated in the centre of the span, a reduction of 0,7x the admissible load is to be taken into account.

F = max. admissible load (daN/m)
 L = support distance (m)
 Max. deflection (m) = L/100

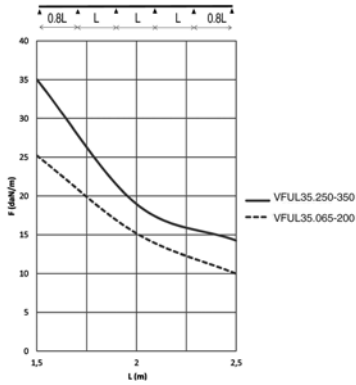

VFUL30.065 coupling only with VFK.

VFUL60

Wire cable tray

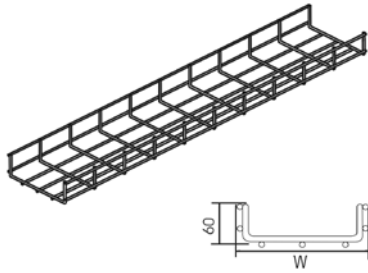

Screen: 50 x 100 mm
 Cross-wire: Ø 3.50 mm
 Lengthwise wire: Ø 4.50 mm

Standard finish	Pre-galvanised
Optional finish HD	Hot-dip galvanised
Optional finish PE	Coating

HD	Reference	↑ mm	↔ mm	↔ mm	↔ mm	kg/m	⊠	Stock	Unit
HD	VFUL60.050	60	50		3000	0.570	30	✓	m
HD	VFUL60.100	60	96		3000	0.830	30	✓	m
HD	VFUL60.150	60	146		3000	0.870	30	✓	m
HD	VFUL60.200	60	197		3000	1.030	30	✓	m
HD	VFUL60.300	60	297		3000	1.330	30	✓	m

Fix with:									
HD	VFKS	55	250	-	-	0.270	20	✓	piece
HD	KPVF	51	248	-	-	0.100	30	✓	piece
HD	VFK	-	-	-	-	0.020	100	✓	piece

LOAD DIAGRAM

This diagram illustrates the permissible uniformly distributed loads applied to multiple supports. They comply with IEC 61537 with connection to 1/5 of the span and the end span = 0,8x the span. When the joint is situated in the centre of the span, a reduction of 0,7x the admissible load is to be taken into account.

F = max. admissible load (daN/m)
 L = support distance (m)
 Max. deflection (m) = L/100

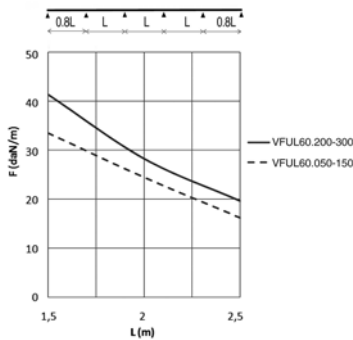

VFU35

Wire cable tray for heavy duty

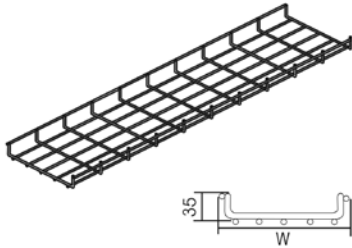

Screen: 50 x 100 mm
Wire: Ø 4.50 mm and 5.50 mm

Standard finish	Pre-galvanised
Optional finish HD	Hot-dip galvanised
Optional finish PE	Coating

HD	Reference	↑ mm	↔ mm	↔ mm	↔ mm	kg/m	⊞	Stock	Unit
HD	VFU35.150	35	148		3000	1.200	30		m
HD	VFU35.250	35	248		3000	1.430	30		m
HD	VFU35.350	35	348		3000	1.780	30		m
HD	VFU35.450	35	448		3000	2.120	30		m
HD	VFU35.550	35	548		3000	2.470	30		m

Fix with:

HD	KPVFL35	45	248	-	-	0.100	30	✓	piece
HD	VFK	-	-	-	-	0.020	100	✓	piece

LOAD DIAGRAM

This diagram illustrates the permissible uniformly distributed loads applied to multiple supports. They comply with IEC 61537 with connection to 1/5 of the span and the end span = 0,8x the span. When the joint is situated in the centre of the span, a reduction of 0,7x the admissible load is to be taken into account.

F = max. admissible load (daN/m)
L = support distance (m)
Max. deflection (m) = L/100

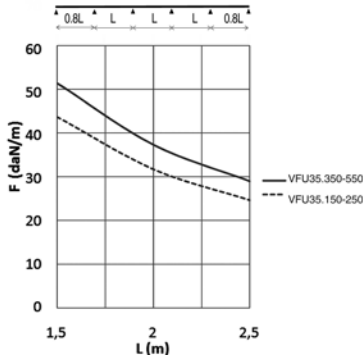

VFU60

Wire cable tray for heavy duty

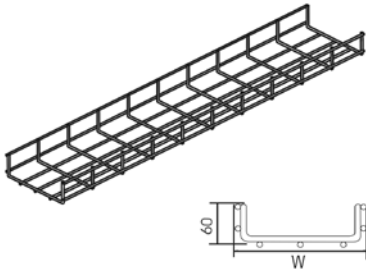

Screen: 50 x 100 mm
Wire: Ø 4.50 mm and 5.50 mm

Standard finish	Pre-galvanised
Optional finish HD	Hot-dip galvanised
Optional finish PE	Coating

HD	Reference	↑ mm	↔ mm	↔ mm	↔ mm	kg/m	⊞	Stock	Unit
HD	VFU60.100	60	99		3000	1.200	30	✓	m
HD	VFU60.200	60	199		3000	1.430	30	✓	m
HD	VFU60.300	60	299		3000	1.780	30	✓	m
HD	VFU60.400	60	399		3000	2.120	30	✓	m
HD	VFU60.500	60	499		3000	2.470	30	✓	m
HD	VFU60.600	60	599		3000	2.810	30	✓	m

Fix with:									
HD	VFKS	55	250	-	-	0.270	20	✓	piece
HD	KPVF	51	248	-	-	0.100	30	✓	piece
HD	VFK	-	-	-	-	0.020	100	✓	piece

LOAD DIAGRAM

This diagram illustrates the permissible uniformly distributed loads applied to multiple supports. They comply with IEC 61537 with connection to 1/5 of the span and the end span = 0,8x the span. When the joint is situated in the centre of the span, a reduction of 0,7x the admissible load is to be taken into account.

F = max. admissible load (daN/m)

L = support distance (m)

Max. deflection (m) = L/100

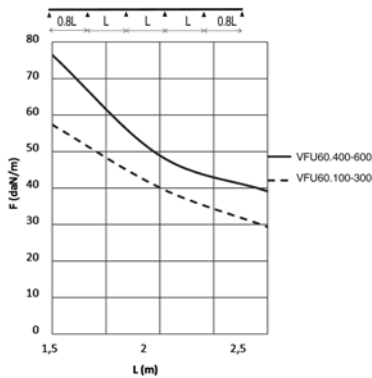

VFU85

Wire cable tray for heavy duty

Screen: 50 x 100 mm
Wire: Ø 4.50 mm and 5.50 mm

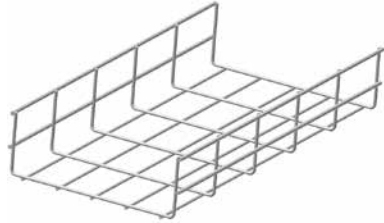

Standard finish	Pre-galvanised
Optional finish HD	Hot-dip galvanised
Optional finish PE	Coating

HD	Reference	↑ mm	↔ mm	↔ mm	↔ mm	kg/m	⊞	Stock	Unit
HD	VFU85.150	85	148		3000	1.430	30		m
HD	VFU85.250	85	248		3000	1.780	30		m
HD	VFU85.350	85	348		3000	2.120	30		m
HD	VFU85.450	85	448		3000	2.470	30		m

Fix with:									
HD	KPVF	51	248	-	-	0.100	30	✓	piece
HD	VFK	-	-	-	-	0.020	100	✓	piece

LOAD DIAGRAM

This diagram illustrates the permissible uniformly distributed loads applied to multiple supports. They comply with IEC 61537 with connection to 1/5 of the span and the end span = 0,8x the span. When the joint is situated in the centre of the span, a reduction of 0,7x the admissible load is to be taken into account.

F = max. admissible load (daN/m)
L = support distance (m)
Max. deflection (m) = L/100

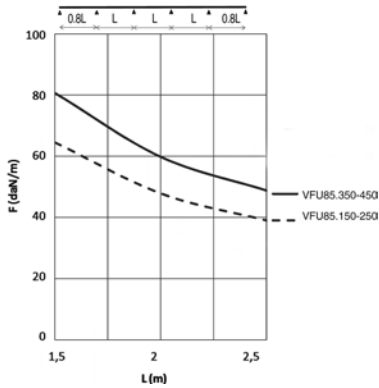

3

VFU110

Wire cable tray for heavy duty

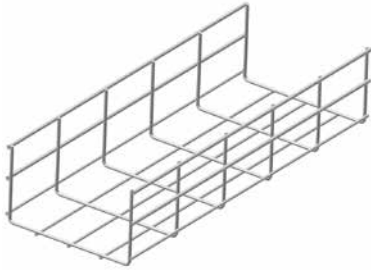

Screen: 50 x 100 mm
Wire: Ø 4.50 mm and 5.50 mm

Standard finish	Pre-galvanised
Optional finish HD	Hot-dip galvanised
Optional finish PE	Coating

HD	Reference	↑ mm	↔ mm	↔ mm	↔ mm	kg/m	⊞	Stock	Unit
HD	VFU110.200	110	199		3000	1.780	30		m
HD	VFU110.300	110	299		3000	2.120	30		m
HD	VFU110.400	110	399		3000	2.470	30		m

Fix with:									
HD	KPVF	51	248	-	-	0.100	30	✓	piece
HD	VFK	-	-	-	-	0.020	100	✓	piece

LOAD DIAGRAM

This diagram illustrates the permissible uniformly distributed loads applied to multiple supports. They comply with IEC 61537 with connection to 1/5 of the span and the end span = 0,8x the span. When the joint is situated in the centre of the span, a reduction of 0,7x the admissible load is to be taken into account.

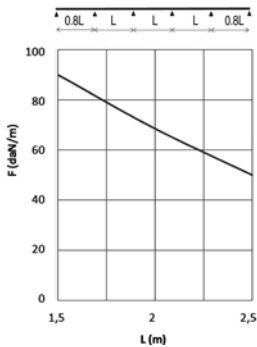

F = max. admissible load (daN/m)
L = support distance (m)
Max. deflection (m) = L/100

GVFUL

G-shaped wire cable tray

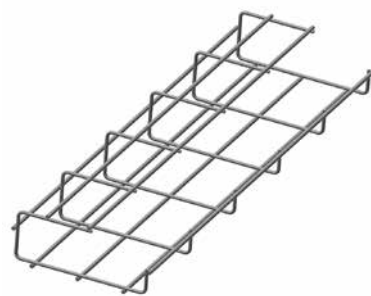

For fixing directly to the ceiling with VFCB.

Standard finish	Pre-galvanised
Optional finish HD	Hot-dip galvanised
Optional finish PE	Coating

HD	Reference	↑ mm	↔ mm	↔ mm	↔ mm	kg/m	⊞	Stock	Unit
HD	GVFUL55.100	55	91		3000	0.830	30	✓	m
HD	GVFUL60.150	64	154		3000	1.030	30	✓	m
HD	GVFUL100.100	102	109		3000	1.030	30	✓	m
HD	GVFUL100.150	105	160		3000	1.330	30	✓	m

Fix with:									
HD	VFK	-	-	-	-	0.020	100	✓	piece

The technical information for this product can be found at the end of this chapter.

D

Universal cover

Especially used for horizontal and vertical sections.
Cover with board height of 10 mm.

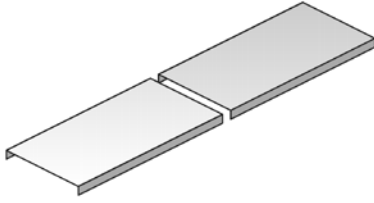

Standard finish	Pre-galvanised
Optional finish HD	Hot-dip galvanised
Optional finish PE	Coating

HD	Reference	↑ mm	↔ mm	↔ mm	↔ mm	kg/m	⊞	Stock	Unit
HD	D050	10	50	0.75	3000	0.350	3	✓	m
HD	D075	10	75	0.75	2000	0.500	20	✓	m
HD	D100	10	100	0.75	2000	0.820	20	✓	m
HD	D150	10	150	0.75	2000	1.170	20	✓	m
HD	D200	10	200	0.75	2000	1.420	20	✓	m
HD	D250	10	250	0.75	2000	1.850	20	✓	m
HD	D300	10	300	1.00	2000	2.100	20	✓	m
HD	D400	10	400	1.25	2000	4.150	20	✓	m
HD	D500	10	500	1.25	2000	5.000	2	✓	m
HD	D600	10	600	1.25	2000	5.650	2	✓	m

Fix with:

-	DCLVF	-	-	-	-	0.005	100	✓	piece
-	DCLVF35	-	-	-	-	0.005	100	✓	piece

Covers with width > 400 mm are delivered with diagonal reinforcements.

DCLVF

Cover clamp clips



For VFU(L)60, VFU85 and VFU110.
Number: 2 pieces per meter.

Standard finish	Stainless Steel
-----------------	-----------------

HD	Reference	↑ mm	↔ mm	↔ mm	↔ mm	kg/piece	⊞	Stock	Unit
-	DCLVF	-	-	-	-	0.005	100	✓	piece

The technical information for this product can be found at the end of this chapter.
To order per full packaging.

DCLVF35

Cover clamp clips



For VFU(L)35.
Number: 2 pieces per meter.

Standard finish		Stainless Steel								
HD	Reference	↑ mm	↔ mm	↔ mm	↔ mm	kg/piece	⊞	Stock	Unit	
-	DCLVF35	-				0.005	100	✓	piece	

The technical information for this product can be found at the end of this chapter.
To order per full packaging.
Do not use with: VFUL30.065.

VFO

Suspension piece for VFU(L)

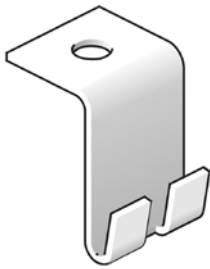

Standard finish		Pre-galvanised								
Optional finish HD		Hot-dip galvanised								
Optional finish PE		Coating								

HD	Reference	↑ mm	↔ mm	↔ mm	↔ mm	kg/piece	⊞	Stock	Unit
HD	VFO	-				0.030	20	✓	piece

To order per full packaging.
For threaded rod suspension M6/M8.
Threaded rod 'TIM6' or 'TIM8' should be ordered separately.

VFOCL

Snap-in suspension for VFU(L)



Standard finish		Electro zinc-plated								
Optional finish HD		Hot-dip galvanised								

HD	Reference	↑ mm	↔ mm	↔ mm	↔ mm	kg/piece	⊞	Stock	Unit
HD	VFOCL	67	25			0.035	20	✓	piece

To order per full packaging.
For threaded rod suspension TIM6 or TIM8.
Threaded rod should be ordered separately.

VFM

Wall bracket for VFU(L)

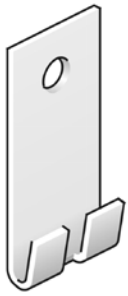

Up to width of 200 mm.

Standard finish	Pre-galvanised
Optional finish HD	Hot-dip galvanised
Optional finish PE	Coating

HD	Reference	↑ mm	↔ mm	↔ mm	↔ mm	kg/piece	⊞	Stock	Unit
HD	VFM	-				0.030	20	✓	piece

To order per full packaging.

VFMM

Wall and mounting bracket for VFU(L)



For VFU(L)60, VFU85, VFU110

Standard finish	Pre-galvanised
Optional finish HD	Hot-dip galvanised
Optional finish PE	Coating

HD	Reference	↑ mm	↔ mm	↔ mm	↔ mm	kg/piece	⊞	Stock	Unit
HD	VFMM	75				0.090	30	✓	piece

The technical information for this product can be found at the end of this chapter.

To order per full packaging.

VFMM35

Wall and mounting bracket for VFU(L)

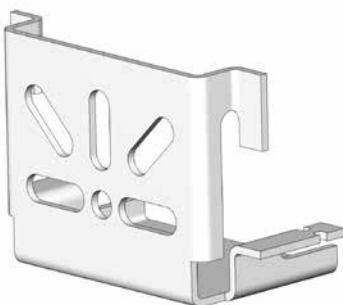

For VFU(L)35

Standard finish	Pre-galvanised
Optional finish HD	Hot-dip galvanised
Optional finish PE	Coating

HD	Reference	↑ mm	↔ mm	↔ mm	↔ mm	kg/piece	⊞	Stock	Unit
HD	VFMM35	57				0.120	30	✓	piece

To order per full packaging.

VFCL

Fixing clips for VFU(L)

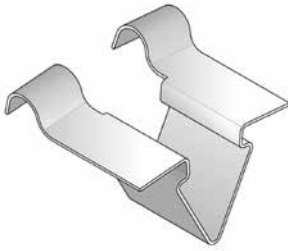

For fixing of wire cable tray on the bracket.

Standard finish

Electro zinc-plated

HD	Reference	↑ mm	↔ mm	↔ mm	↔ mm	kg/piece	📦	Stock	Unit
-	VFCL	-				0.010	100	✓	piece

To order per full packaging.

VFCLB

Central suspension bracket



Standard finish

Pre-galvanised

Optional finish HD

Hot-dip galvanised

Optional finish PE

Coating

HD	Reference	↑ mm	↔ mm	↔ mm	↔ mm	kg/piece	📦	Stock	Unit
HD	VFCLB	-				0.035	60	✓	piece

To order per full packaging.

2 pieces for threaded rod suspension M6/M8.

Can be used for wire cable trays: VFUL35.100, VFU(L)60.100, VFUL60.150

1 piece for direct mounting to the ceiling

Can be used for wire cable trays: GVFUL55.100, GVFUL60.150, GVFUL100.100 and GVFUL100.150.

OBG

Upper bracket

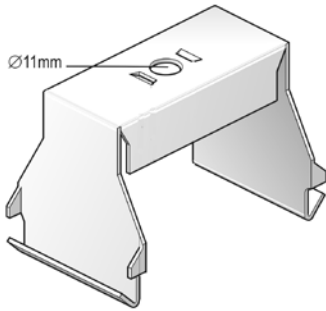

To mount cable trays with partition.

Standard finish	Pre-galvanised
Optional finish HD	Hot-dip galvanised
Optional finish PE	Coating

	Max. Load (in daN)
OBG050	200
OBG075	200
OBG100	200
OBG150	200
OBG200	200
OBG250	150
OBG300	150
OBG400	90

HD	Reference	↑ mm	↔ mm	↔ mm	↔ mm	kg/piece	📦	Stock	Unit
HD	OBG050	64	55		-	0.100	12	✓	piece
HD	OBG075	64	80		-	0.130	12	✓	piece
HD	OBG100	64	105		-	0.140	12	✓	piece
HD	OBG150	64	155		-	0.190	12	✓	piece
HD	OBG200	64	205		-	0.220	12	✓	piece
HD	OBG250	64	255		-	0.270	12	✓	piece
HD	OBG300	64	305		-	0.310	6	✓	piece
HD	OBG400	64	405		-	0.390	6	✓	piece

To order per full packaging.
To be mounted with threaded rod TIM8 or TIM10.

OBGVF

Open C-suspension bracket for VFU(L)

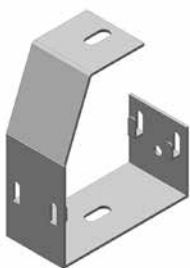

Max. load	15 daN
Standard finish	Pre-galvanised

HD	Reference	↑ mm	↔ mm	↔ mm	↔ mm	kg/piece	📦	Stock	Unit
-	OBGVF050	135	55		-	0.175	12	✓	piece
-	OBGVF100	135	102		-	0.245	12	✓	piece

The technical information for this product can be found at the end of this chapter.

To order per full packaging.
To be mounted with threaded rod TIM6 or TIM8.
Max. load (in daN): uniformly distributed over complete width of cantilever brackets.

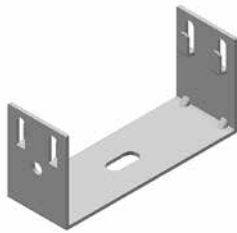
BGVF**External suspension bracket for VFU(L)**

Max. load	70 daN
Standard finish	Pre-galvanised

HD	Reference	↑ mm	↔ mm	↔ mm	↔ mm	kg/piece	📦	Stock	Unit
-	BGVF050	45	55		-	0.106	12	✓	piece
-	BGVF100	52	102		-	0.154	24	✓	piece

The technical information for this product can be found at the end of this chapter.

To order per full packaging.

To be mounted with threaded rod TIM6 or TIM8.

Max. load (in daN): uniformly distributed over complete width of cantilever brackets.

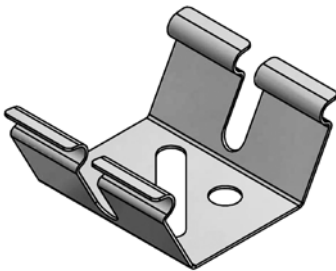
VFVLB**Floor bracket for VFU(L)**

Standard finish	Stainless Steel
-----------------	-----------------

HD	Reference	↑ mm	↔ mm	↔ mm	↔ mm	kg/piece	📦	Stock	Unit
-	VFVLB	-			-	0.030	30	✓	piece

To order per full packaging.

Up to width 250 mm, minimum 2 pieces per meter.

As from width 300 mm, minimum 4 pieces per meter.

ZCL

Z-support clippable

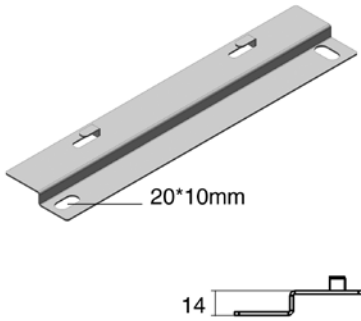

Standard finish	Pre-galvanised
Optional finish HD	Hot-dip galvanised

	Max. load (in daN)
ZCL100	150
ZCL150	150
ZCL200	120
ZCL300	105
ZCL400	90
ZCL500	80
ZCL600	65

HD	Reference	↑ mm	↔ mm	↔ mm	↔ mm	kg/piece	⊞	Stock	Unit
HD	ZCL100	14	60		180	0.135	12	✓	piece
HD	ZCL150	14	60		230	0.165	12	✓	piece
HD	ZCL200	14	60		280	0.210	12	✓	piece
HD	ZCL300	14	60		380	0.265	12	✓	piece
HD	ZCL400	14	60		480	0.315	12	✓	piece
HD	ZCL500	14	60		580	0.365	12	✓	piece
HD	ZCL600	14	60		680	0.415	12	✓	piece

To order per full packaging.

MPVFCL

Profile for VFU(L)

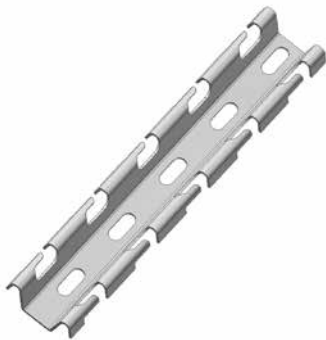

Standard finish	Pre-galvanised
Optional finish HD	Hot-dip galvanised

HD	Reference	↑ mm	↔ mm	↔ mm	↔ mm	kg/m	⊞	Stock	Unit
HD	MPVFCL3000	27	55		3000	1.009	30		m

The technical information for this product can be found at the end of this chapter.

Do not use with: VFUL30.065, VFUL35.150, VFU35.150, VFUL 60.050

COMEGACLU170**Open suspension bracket universal**

Useful for direct mounting to the ceiling or with threaded rod TIM8 or TIM10.

Standard finish	Pre-galvanised
Optional finish HD	Hot-dip galvanised
Optional finish PE	Coating

	Max. load (in daN)	A
COMEGACLU170.150	60	182
COMEGACLU170.200	60	232
COMEGACLU170.300	50	332
COMEGACLU170.400	40	432

HD	Reference	↑ mm	↔ mm	↔ mm	↔ mm	kg/piece	⊞	Stock	Unit
HD	COMEGACLU170.150	170	182		-	0.460	12	✓	piece
HD	COMEGACLU170.200	170	232		-	0.540	12	✓	piece
HD	COMEGACLU170.300	170	332		-	0.700	6	✓	piece
HD	COMEGACLU170.400	170	432		-	0.860	6	✓	piece

To order per full packaging.

Fixing of the cable tray by VM6.10.

Use the VOMEGA to avoid compression of the profile.

Max. load (in daN): uniformly distributed over complete width of cantilever brackets.

Do not use with: VFUL30.065, VFUL35.150, VFU35.150, VFUL 60.050

COMEGACLU290

Open suspension bracket universal



Useful for direct mounting to the ceiling or with threaded rod TIM8 or TIM10.

Standard finish	Pre-galvanised
Optional finish HD	Hot-dip galvanised
Optional finish PE	Coating

	Max. load (in daN)
COMEGACLU290.100	70
COMEGACLU290.150	60
COMEGACLU290.200	60
COMEGACLU290.250	50
COMEGACLU290.300	50
COMEGACLU290.400	40

HD	Reference	↑ mm	↔ mm	↔ mm	↔ mm	kg/piece	⊞	Stock	Unit
HD	COMEGACLU290.100	290	145		-	0.520	12	✓	piece
HD	COMEGACLU290.150	290	195		-	0.560	12	✓	piece
HD	COMEGACLU290.200	290	245		-	0.620	12	✓	piece
HD	COMEGACLU290.250	290	295		-	0.760	6	✓	piece
HD	COMEGACLU290.300	290	345		-	0.820	6	✓	piece
HD	COMEGACLU290.400	290	445		-	0.930	6	✓	piece

To order per full packaging.

Fixing of the cable tray by VM6.10.

Use the VOMEGA to avoid compression of the profile.

Max. load (in daN): uniformly distributed over complete width of cantilever brackets.

Do not use with: VFUL30.065, VFUL35.150, VFU35.150, VFUL 60.050.

LOMEGACLU150

Wall bracket universal



Standard finish	Pre-galvanised
Optional finish HD	Hot-dip galvanised
Optional finish PE	Coating

	Max. load (in daN)
LOMEGACLU150.100	110
LOMEGACLU150.150	100
LOMEGACLU150.200	90
LOMEGACLU150.250	80
LOMEGACLU150.300	70
LOMEGACLU150.400	50
LOMEGACLU150.500	40
LOMEGACLU150.600	30

HD	Reference	↑ mm	↔ mm	↔ mm	↔ mm	kg/piece	📦	Stock	Unit
HD	LOMEGACLU150.100	150	145		-	0.300	12	✓	piece
HD	LOMEGACLU150.150	150	195		-	0.320	12	✓	piece
HD	LOMEGACLU150.200	150	245		-	0.340	12	✓	piece
HD	LOMEGACLU150.250	150	295		-	0.450	12	✓	piece
HD	LOMEGACLU150.300	150	345		-	0.490	12	✓	piece
HD	LOMEGACLU150.400	150	445		-	0.540	6	✓	piece
HD	LOMEGACLU150.500	150	545		-	0.710	6	✓	piece
HD	LOMEGACLU150.600	150	645		-	0.770	6	✓	piece

To order per full packaging.

Fixing of the cable tray by VM6.10.

Use the VOMEGA to avoid compression of the profile.

Max. load (in daN): uniformly distributed over complete width of cantilever brackets.

Do not use with: VFUL30.065, VFUL35.150, VFU35.150, VFUL 60.050.

VMB

Floor and wall bracket

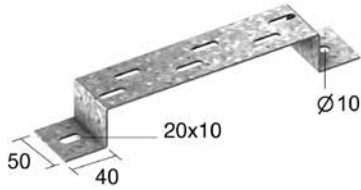

Suitable as floor-, wall-, and suspension bracket.

Max. load	200 daN
Standard finish	Pre-galvanised
Optional finish HD	Hot-dip galvanised
Optional finish PE	Coating

HD	Reference	↑ mm	↔ mm	↔ mm	↔ mm	kg/piece	📦	Stock	Unit
HD	VMB100	40	100		-	0.190	30	✓	piece
HD	VMB150	40	150		-	0.220	30	✓	piece
HD	VMB200	40	200		-	0.260	30	✓	piece
HD	VMB300	40	300		-	0.330	30	✓	piece
HD	VMB400	40	400		-	0.390	30	✓	piece
HD	VMB500	40	500		-	0.460	30	✓	piece
HD	VMB600	40	600		-	0.530	30	✓	piece

The technical information for this product can be found at the end of this chapter.

To order per full packaging.

Floor bracket and suspension bracket: to mount with VFCL.

Wall bracket: to mount with VFK.

SLOS

Division plate free

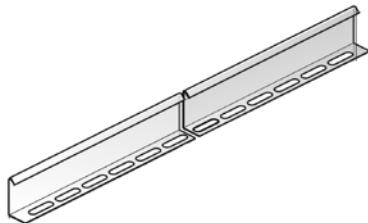

Standard finish	Pre-galvanised
Optional finish HD	Hot-dip galvanised
Optional finish PE	Coating

HD	Reference	↑ mm	↔ mm	↔ mm	↔ mm	kg/m	📦	Stock	Unit
HD	SLOS35	35			3000	0.330	150	✓	m
HD	SLOS60	60			3000	0.511	120	✓	m
HD	SLOS85	85			3000	0.680	60	✓	m
HD	SLOS110	110			3000	0.820	30	✓	m

Fix with:

-	VFSLOSCL	-	-	-	-	0.003	100	✓	piece
HD	VFK	-	-	-	-	0.020	100	✓	piece

The technical information for this product can be found at the end of this chapter.

Fixing set: 1 per meter.

VFSLOSCL

Clips for fixing SLOS to VFU(L)



Clips for fixing the division plate SLOS to VFU(L).

Standard finish	Stainless Steel
-----------------	-----------------

HD	Reference	↑ mm	↔ mm	↔ mm	↔ mm	kg/piece	📦	Stock	Unit
-	VFSLOSCL	-				0.003	100	✓	piece

To order per full packaging.

VFK

Joining clamp

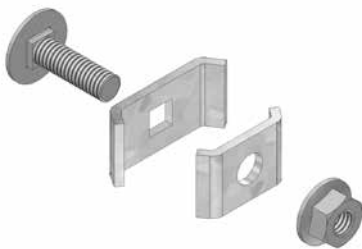

Standard finish	Pre-galvanised
Optional finish HD	Hot-dip galvanised
Optional finish PE	Coating

HD	Reference	↑ mm	↔ mm	↔ mm	↔ mm	kg/piece	📦	Stock	Unit
HD	VFK	-				0.020	100	✓	piece

The technical information for this product can be found at the end of this chapter.

To order per full packaging.
Included: Bolt RBK6.20 and nut RM6.

VFKG30

Joining clamp for VFU(L)



Standard finish	Pre-galvanised
Optional finish HD	Hot-dip galvanised
Optional finish PE	Coating

HD	Reference	↑ mm	↔ mm	↔ mm	↔ mm	kg/piece	📦	Stock	Unit
HD	VFKG30	-	30			0.020	100	✓	piece

To order per full packaging.

VFKK25

Joining clamp for VFU(L)

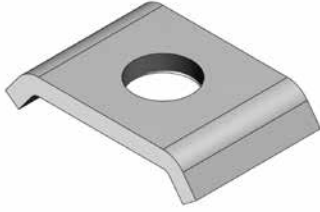

Standard finish	Pre-galvanised
Optional finish HD	Hot-dip galvanised
Optional finish PE	Coating

HD	Reference	mm	mm	mm	mm	kg/piece		Stock	Unit
HD	VFKK25	-	25		-	0.020	100	✓	piece

To order per full packaging.

VFKS

Support joiner for VFU(L)



For maximum stability and safety. Can only be used with VFU(L)60

Standard finish	Pre-galvanised
Optional finish HD	Hot-dip galvanised
Optional finish PE	Coating

HD	Reference	mm	mm	mm	mm	kg/piece		Stock	Unit
HD	VFKS	55	250		-	0.270	20	✓	piece

To order per full packaging.
Included: 3x bolt RBK6.20, 3x nut RM6 and 3x VFKG30.

KPVF

Snap-on joiner for VFU(L)



For quick joining without bolts and nuts. Can only be used with VFU(L)60, VFU85, VFU110.

Standard finish	Pre-galvanised
Optional finish HD	Hot-dip galvanised
Optional finish PE	Coating

HD	Reference	↑ mm	↔ mm	↔ mm	↔ mm	kg/piece	📦	Stock	Unit
HD	KPVF	51	248		-	0.100	30	✓	piece

To order per full packaging.

KPVFL35

Snap quick-joiner for VFU(L)35



For quick joining of VFUL35 without bolts and nuts.

Standard finish	Pre-galvanised
Optional finish HD	Hot-dip galvanised
Optional finish PE	Coating

HD	Reference	↑ mm	↔ mm	↔ mm	↔ mm	kg/piece	📦	Stock	Unit
HD	KPVFL35	45	248		-	0.100	30	✓	piece

To order per full packaging.
Do not use with VFUL30.065.

V35.200

Jointing plate

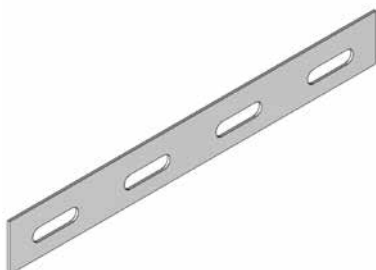

Standard finish	Pre-galvanised
Optional finish HD	Hot-dip galvanised
Optional finish PE	Coating

HD	Reference	↑ mm	↔ mm	↔ mm	↔ mm	kg/piece	📦	Stock	Unit
HD	V35.200	25	200		-	0.040	48	✓	piece

To order per full packaging.

VFKNIP

Bolt cutter

Bolt cutter with offset cut



HD	Reference	↑ mm	↔ mm	↔ mm	↔ mm	kg/piece	📦	Stock	Unit
-	VFKNIP	-				0.750	1	✓	piece

GVFUL

Technical information

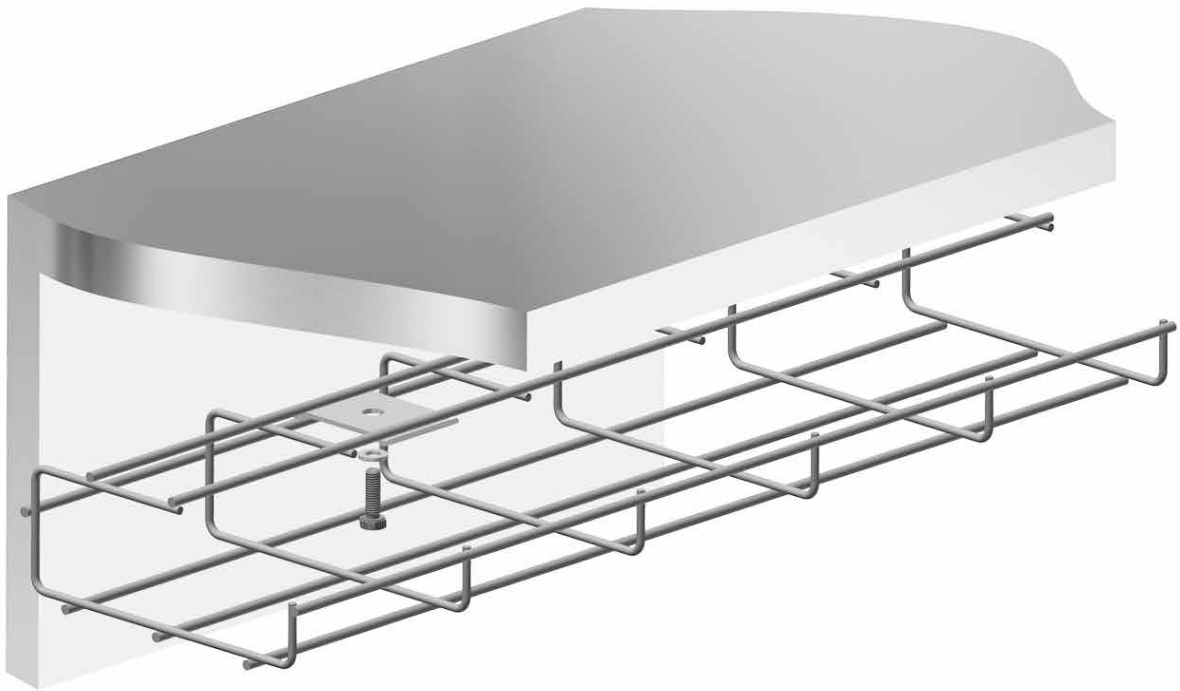

DCLVF

Technical information

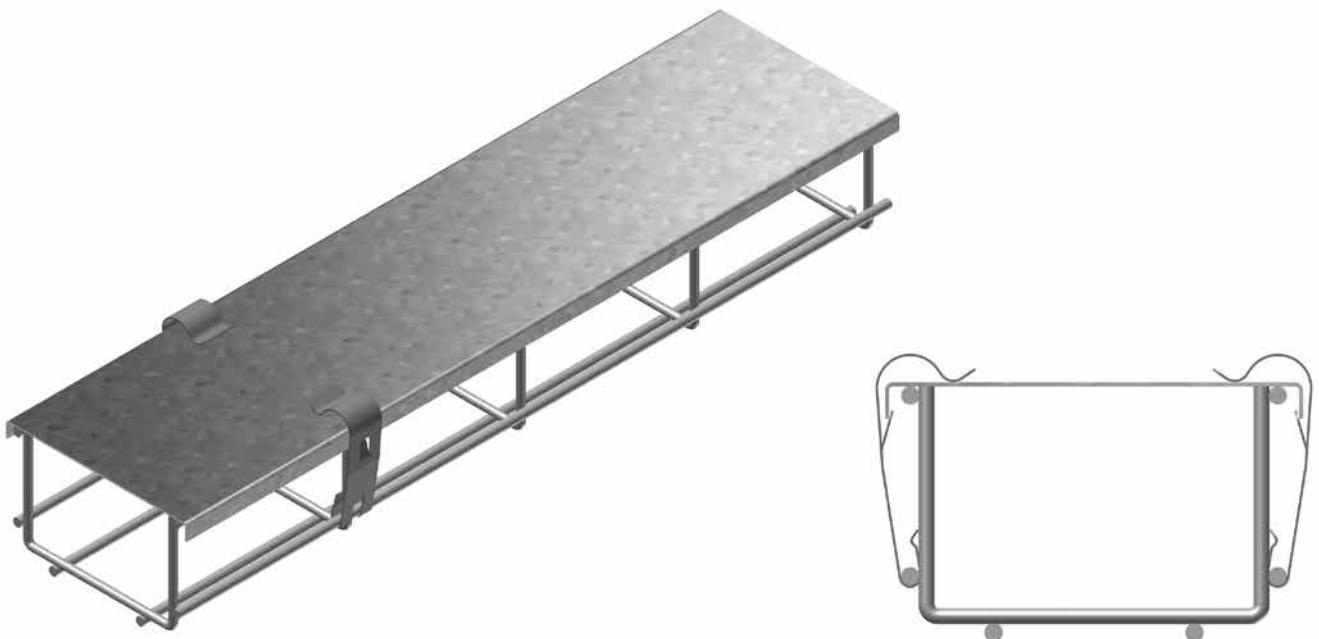

For VFU(L)60, VFU85 and VFU110.

DCLVF35

Technical information

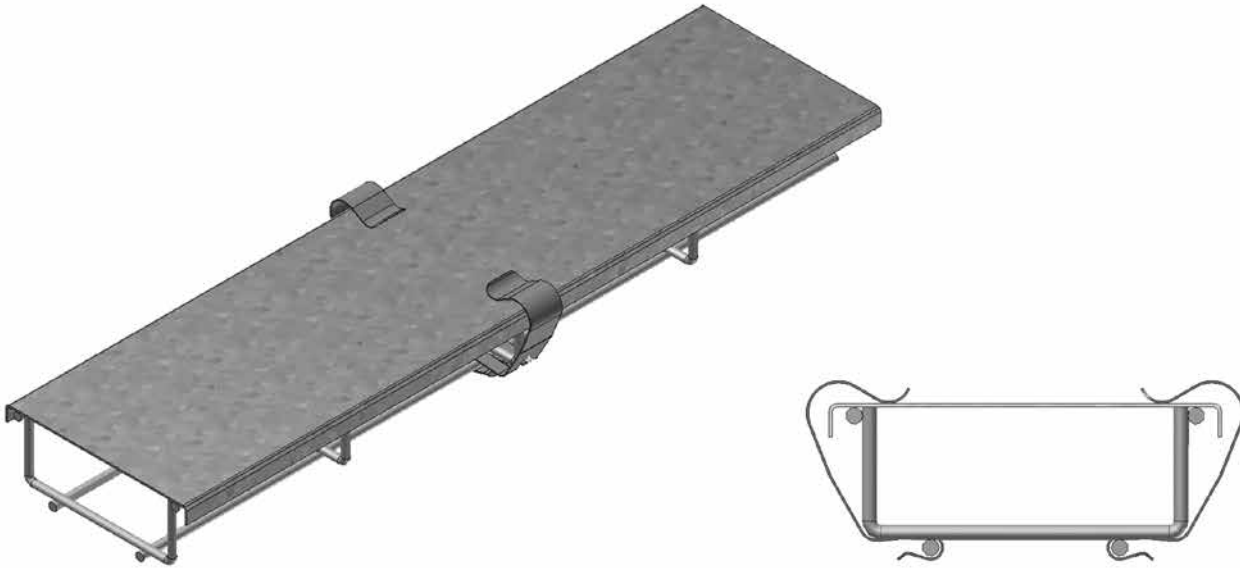

For VFU(L)35

VFMM

Technical information

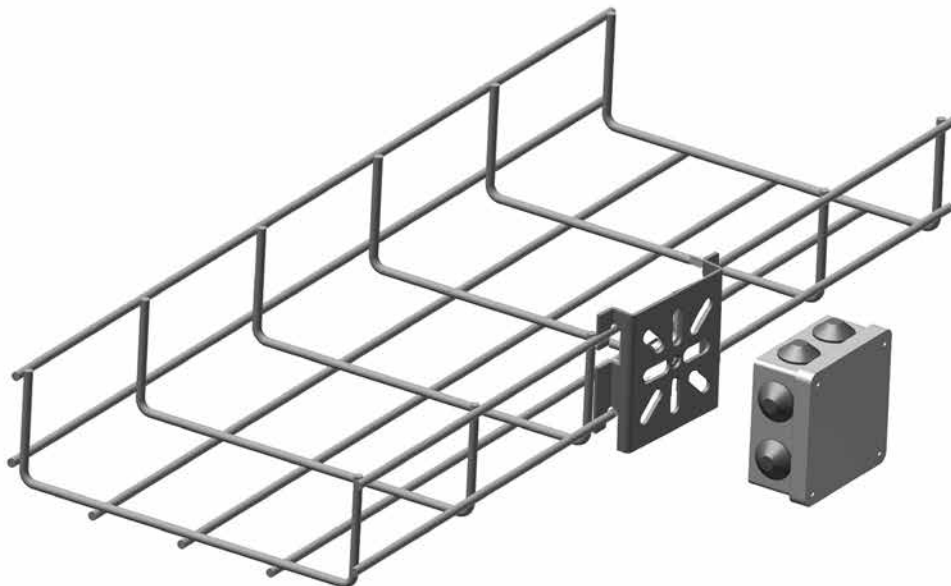

For fixing of contact boxes and wall fixing.

OBGVF

Technical information

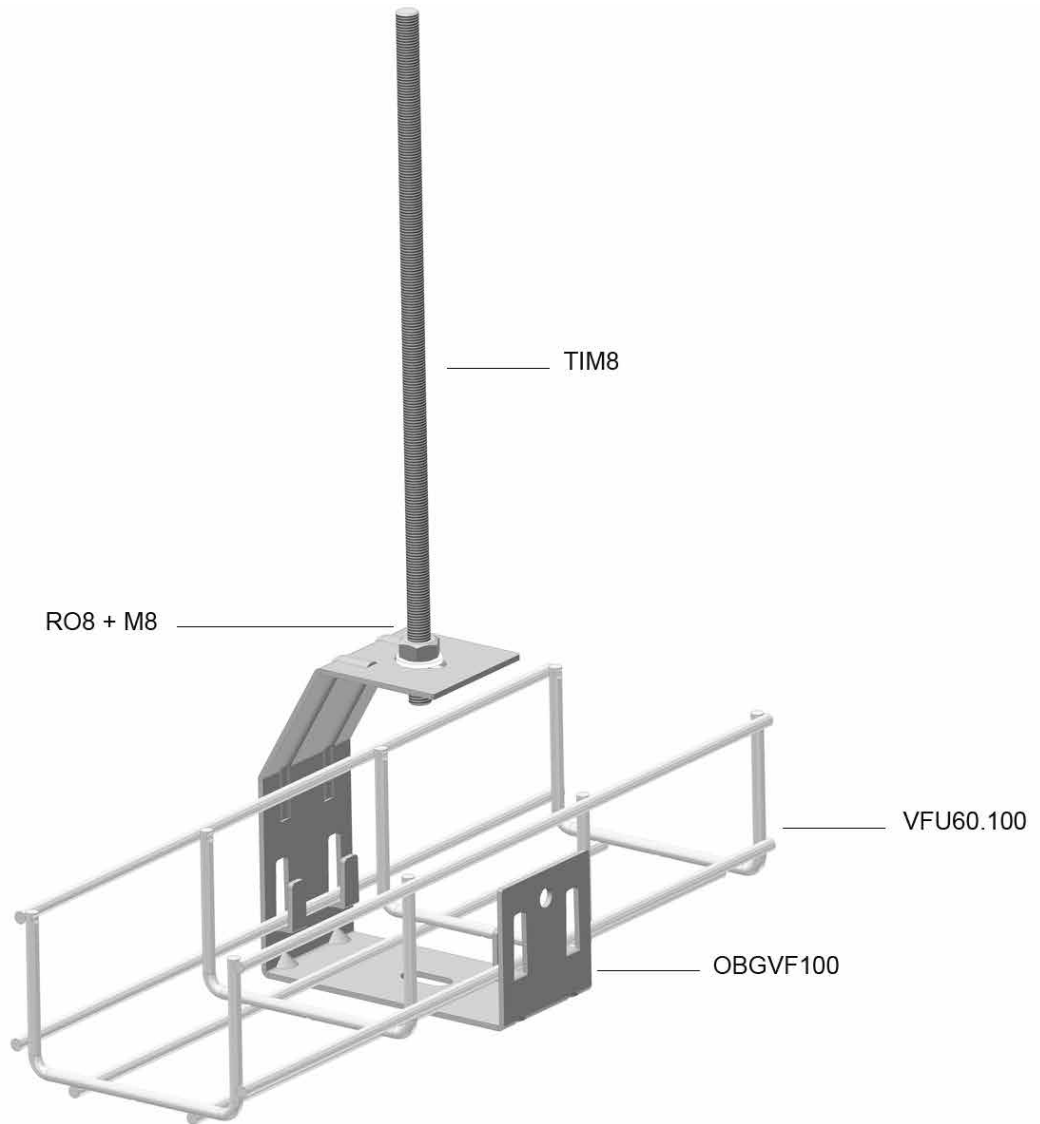

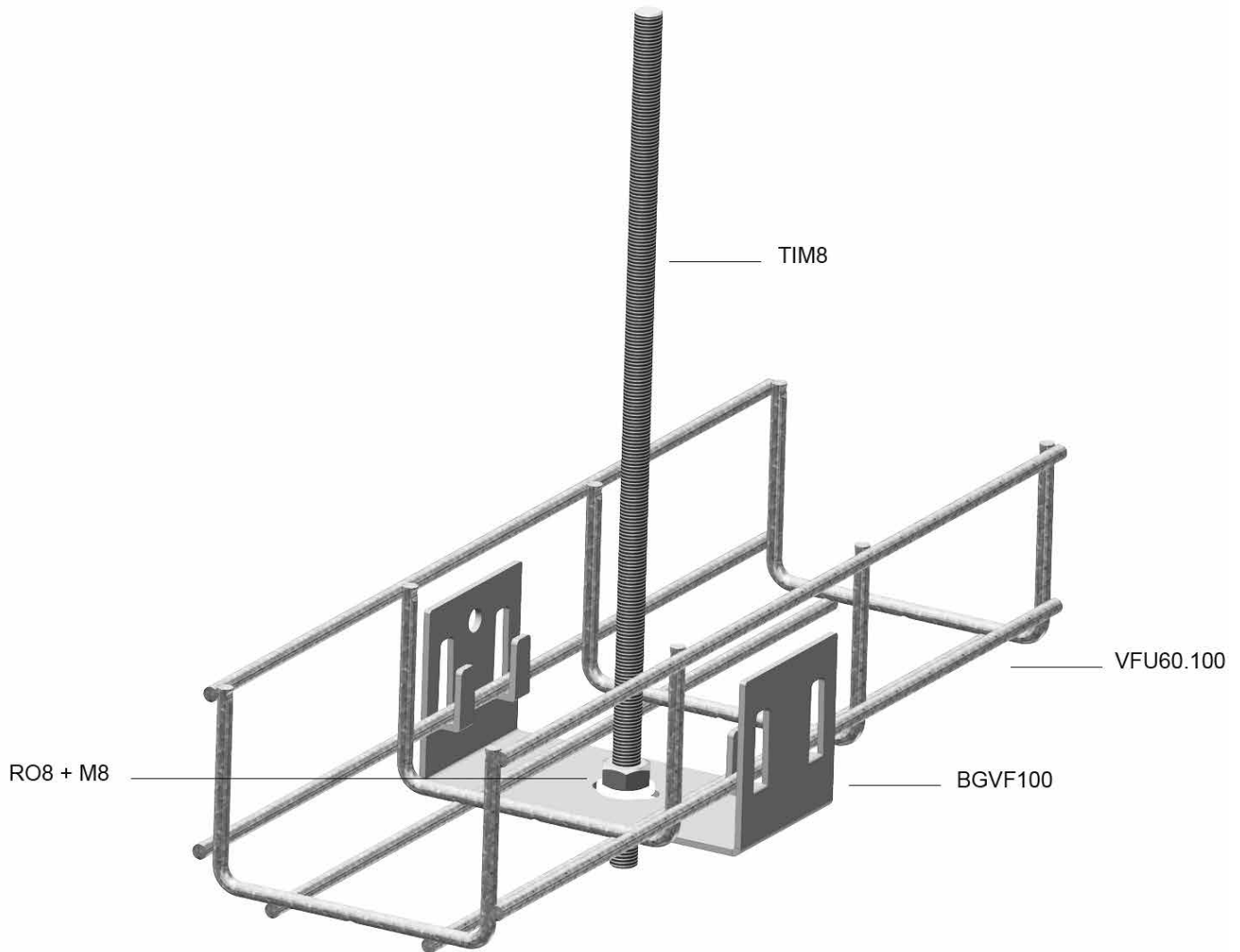
BGVF**Technical information**

MPVFCL

Technical information

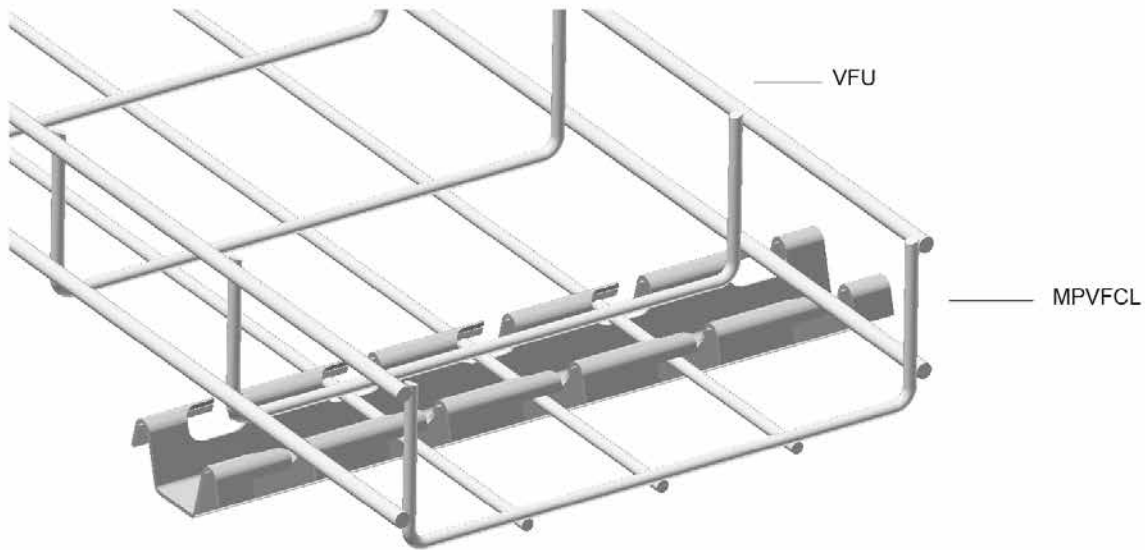

VMB

Technical information

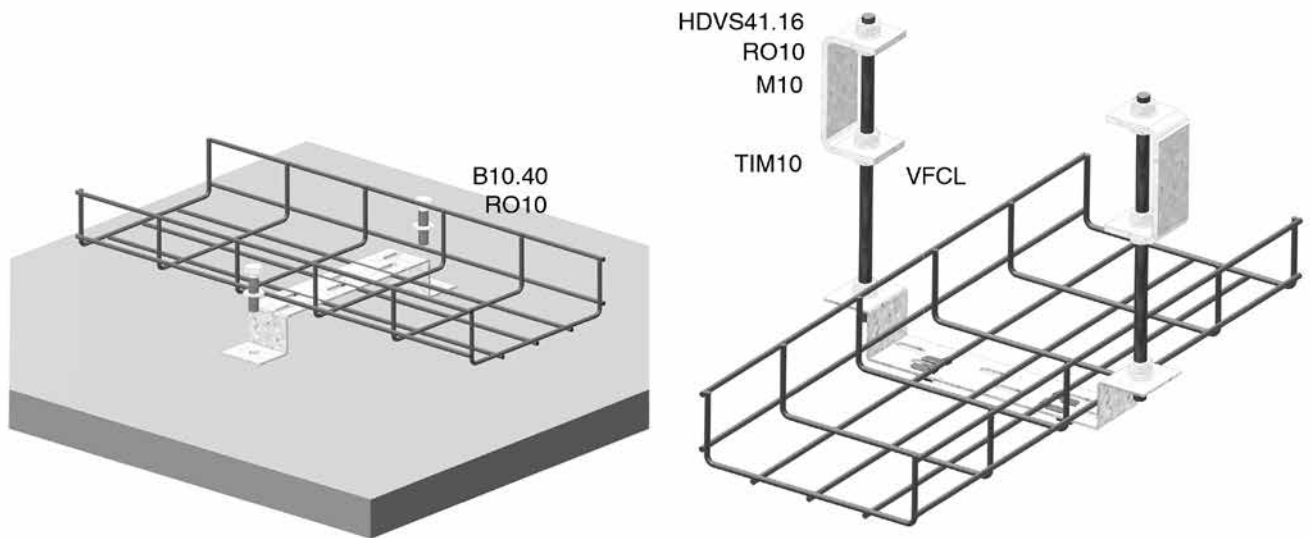

Suitable as floor-, wall-, and suspension bracket.
 Floor bracket and suspension bracket : to mount with VFCL.
 Wall bracket : to mount with VFK.

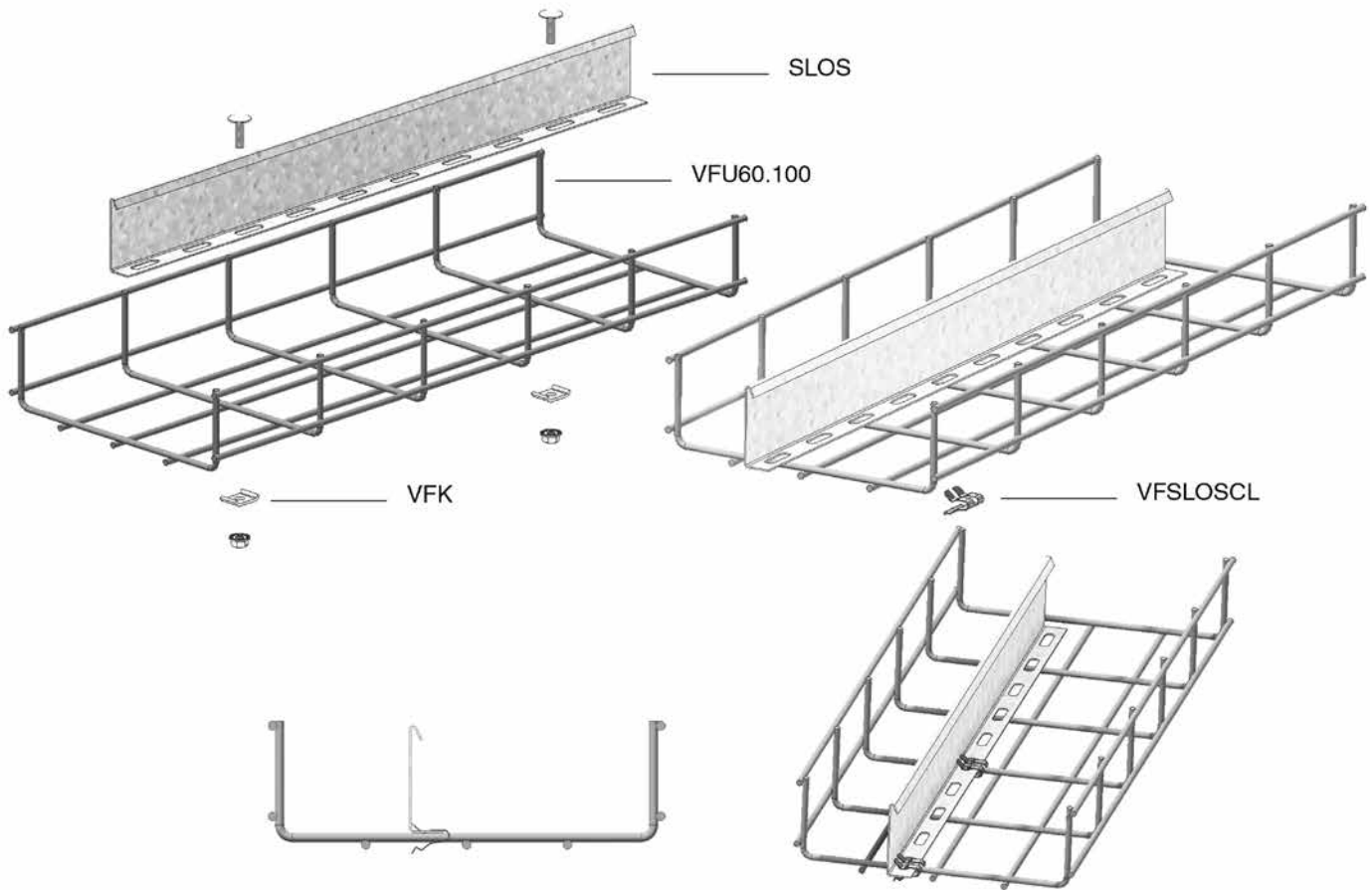
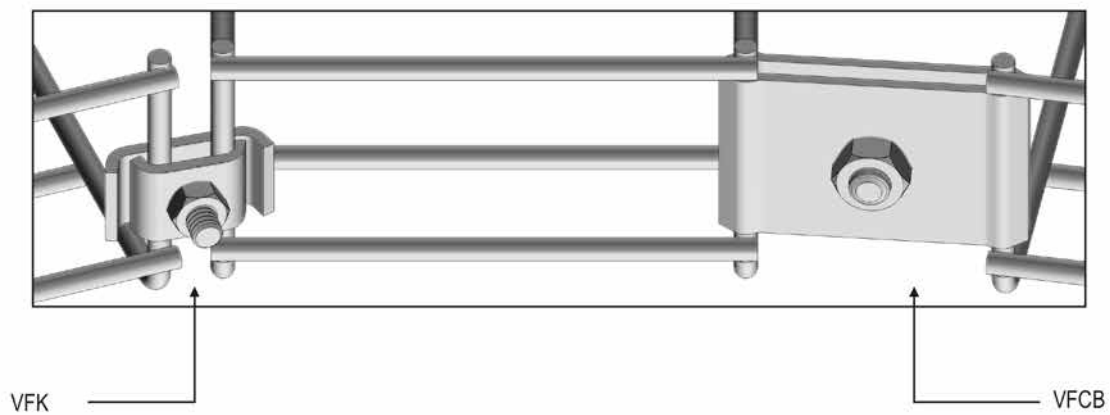
SLOS**Technical information****VFK****Technical information**

HOW TO CUT THE WIRE

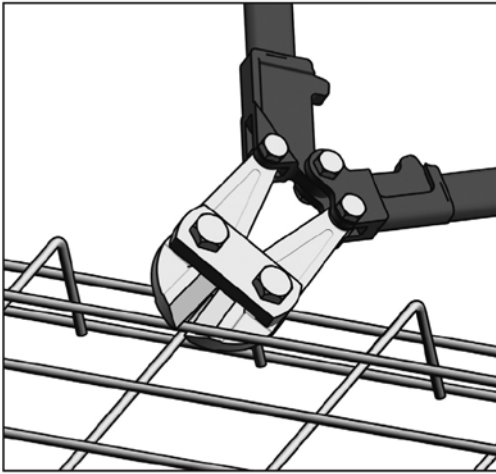

The shape of the cable basket can be changed to your requirements. For cutting of the wire mesh, we recommend the use of a professional set of cutting pliers with offset cut (drawing here below). The cutting of the wire is by preference being done as close as possible to the crossing of the wires, in order to prevent cable damage.

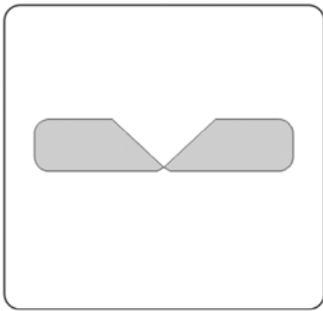

yes
Offset cut

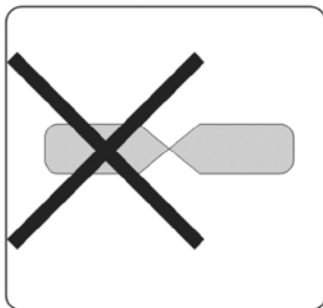

no
Central cut

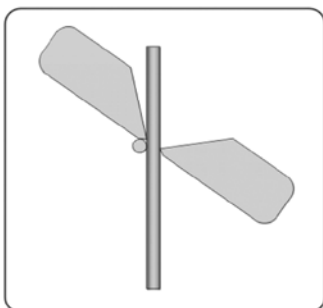

Placing of the clamping jaws

BEND WITH LARGE RADIUS

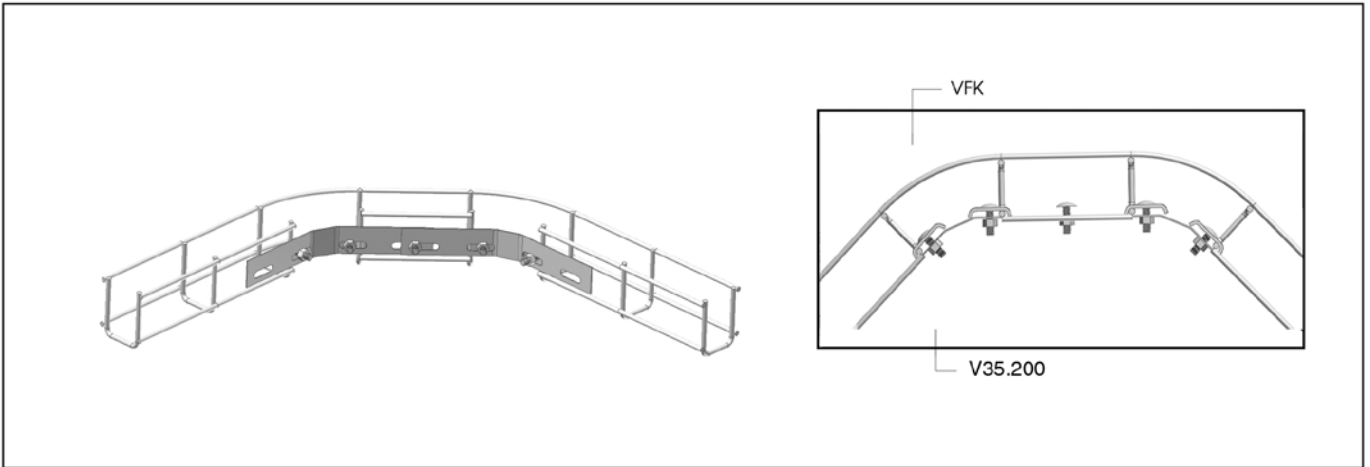

Widths 100 - 550 mm

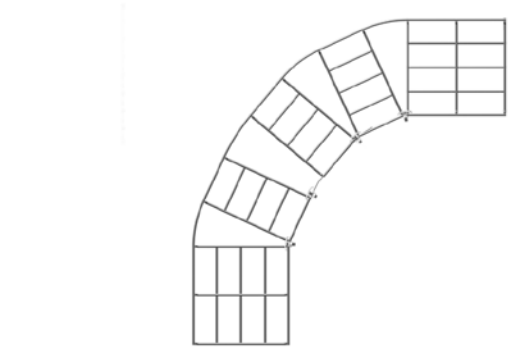
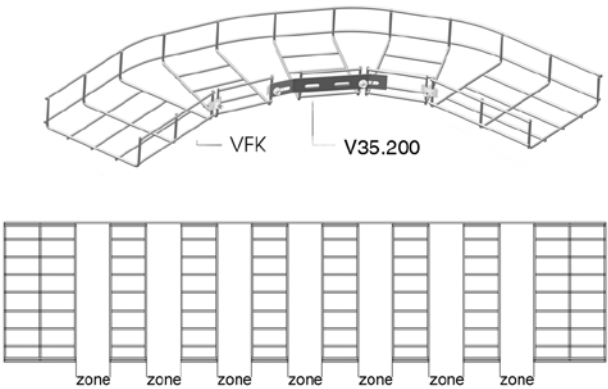

Width	Height	Zones	VFK	VFCB	V35.200
100	35/60	3	2	2	1
150	35/60	3	4	-	1
200	35/60	4	4	-	1
250	35	5	6	-	1
300	60	5	5	-	-
350	35	6	6	-	-
400	60	7	7	-	-
450	35	8	8	-	-
500	60	9	9	-	-
550	35	10	10	-	-

Fixation possibilities

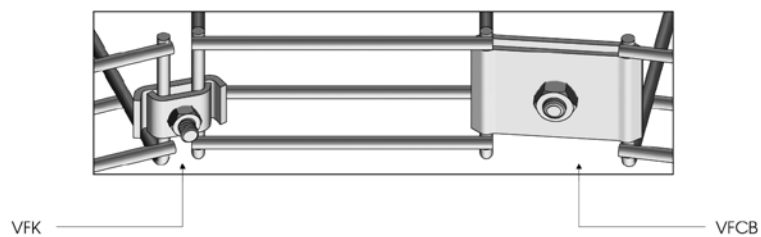

BEND WITH SMALL RADIUS

Method A

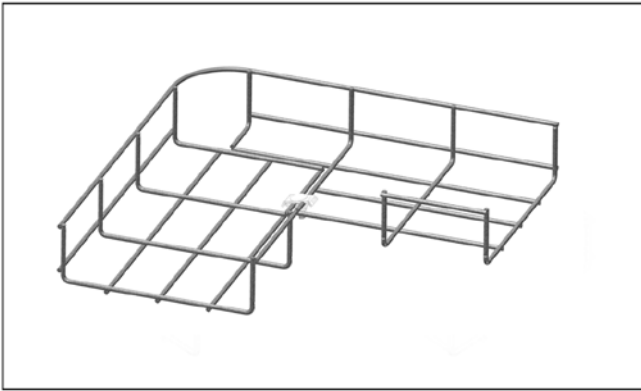

Method B

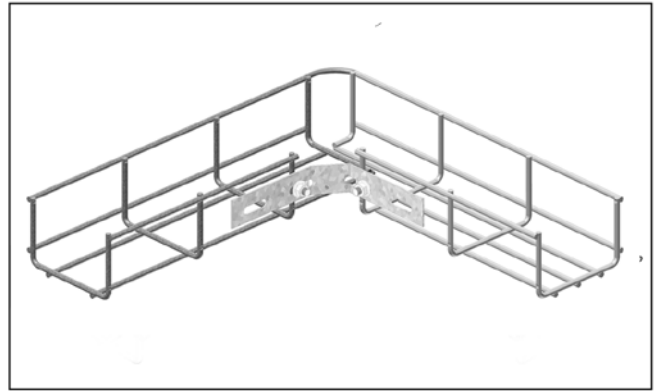

Width	Height	VFK	V35.200	Zones	Mounted	Method	Lenght
100	35/60	2	1			B	269,5
150	35	2	1			B	269,5
150	60	2	1			B	269,5
200	35	1	0			B	369,5
200	60	1	0			A	369,5
250	35	2	1			B	369,5
300	60	2	0			A	469,5
350	35	2	1			B	469,5
400	60	2	0			A	569,5
450	35	2	1			B	569,5
500	60	3	0			A	669,5
550	35	2	1			B	669,5
600	60	4	0			A	679,5

To make a small radius bend, one has to take a length of cable basket and cut away the necessary zones out of the bottom and the side. Then bend the cable basket to an angle of 90° and connect both ends by means of method A or B as mentioned in the table above. For the cable basket, width 50, only a large radius can be made.

T-PIECE

Type Wire cable tray

Reference	Number of zones to cut away
VFU(L)60.100	2
VFUL60.150	3
VFU85.100	2
VFU85.250	4
VFU85.350	5
VFU85.450	6

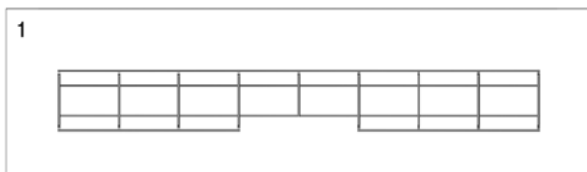

Equal for all widths

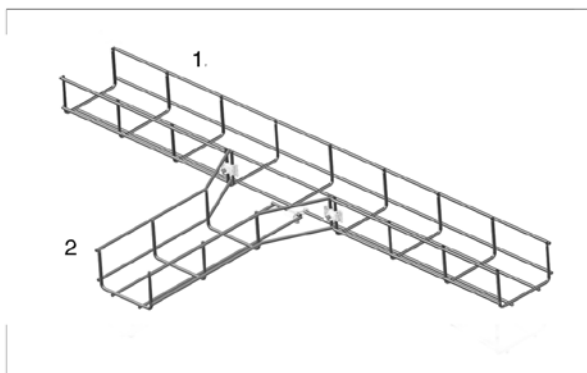
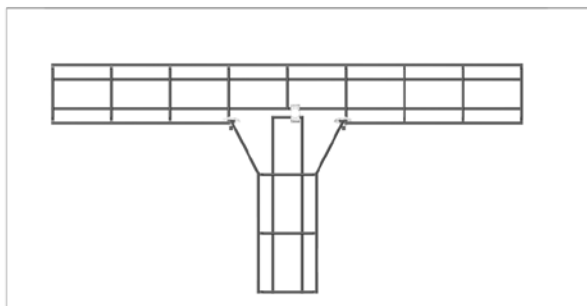
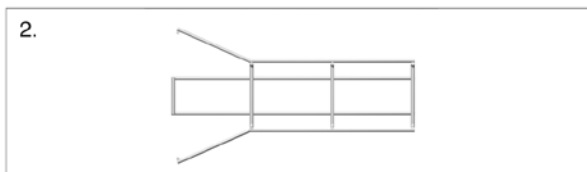

Type Wire cable tray

Reference	Number of zones to cut away
VFU(L)60.200	4
VFU(L)60.300	5
VFU60.400	6
VFU60.500	7
VFU60.600	8
VFU85.150	3
VFU110.200	4
VFU110.300	5
VFU110.400	6

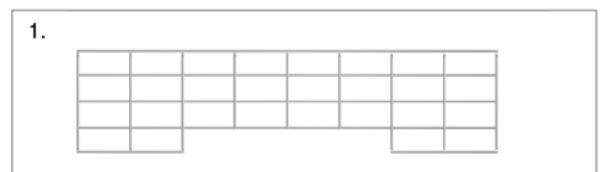

Equal for all widths

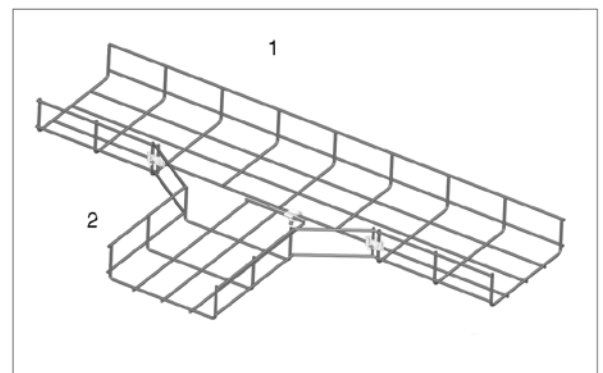
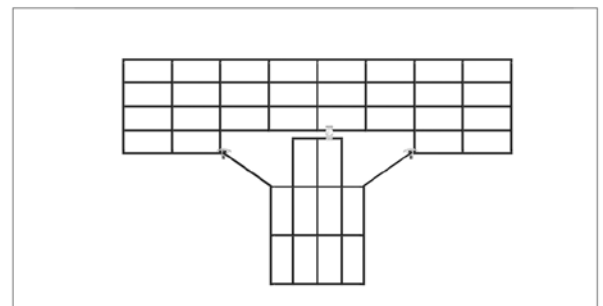
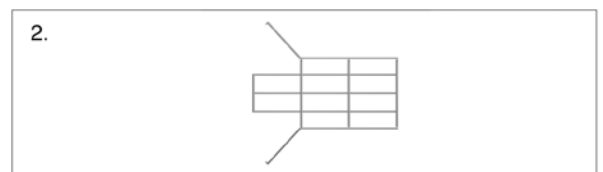

A T-piece is being made by cutting away the side of the basket tray (no 1), according to the data mentioned in the table above. Always the same zones will have to be cut away in basket tray (no 2). The remaining sides are being bend across each other. The basket trays are being coupled with VFK.

CROSS SECTION

Type Wire cable tray

Reference	Number of zones to cut away
VFU(L)60.100	2x 2
VFUL60.150	2x 3
VFU85.100	2x 2
VFU85.250	2x 4
VFU85.350	2x 5
VFU85.450	2x 6

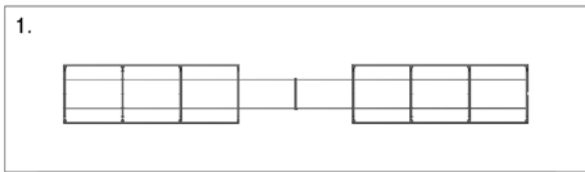

Equal for all widths

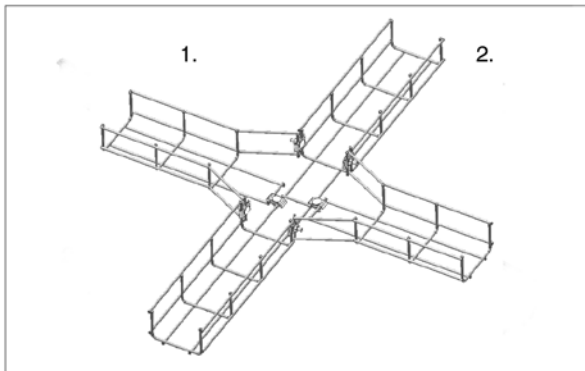
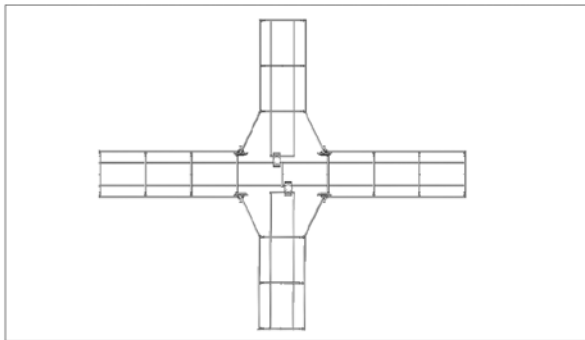
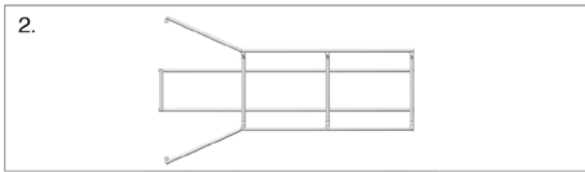

Type Wire cable tray

Reference	Number of zones to cut away
VFU(L)60.200	2x 4
VFU(L)60.300	2x 5
VFU60.400	2x 6
VFU60.500	2x 7
VFU60.600	2x 8
VFU85.150	2x 3
VFU110.200	2x 4
VFU110.300	2x 5
VFU110.400	2x 6

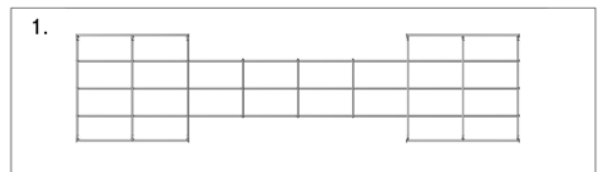

Equal for all widths

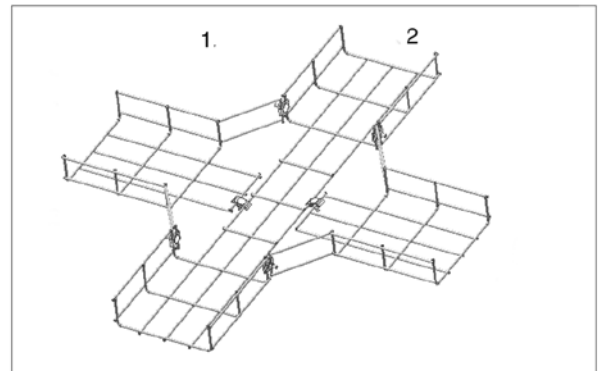
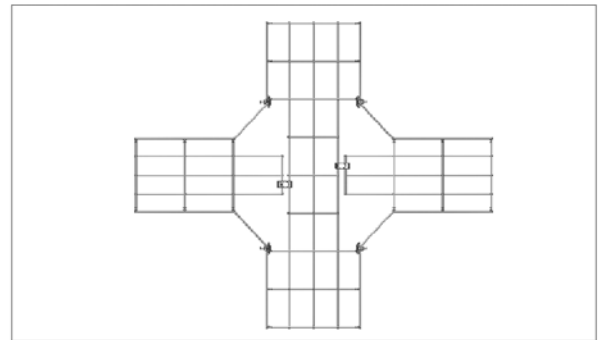
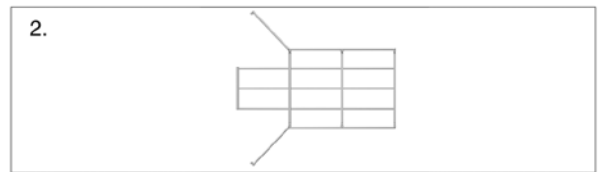

A cross-piece is being made by cutting away the side of the basket tray (no 1), according to the data mentioned in the table above. Always the same zones will have to be cut away in basket tray (no 2). The remaining sides are being bend across each other. The basket trays are being coupled with VFK.

LEVEL DIFFERENCES

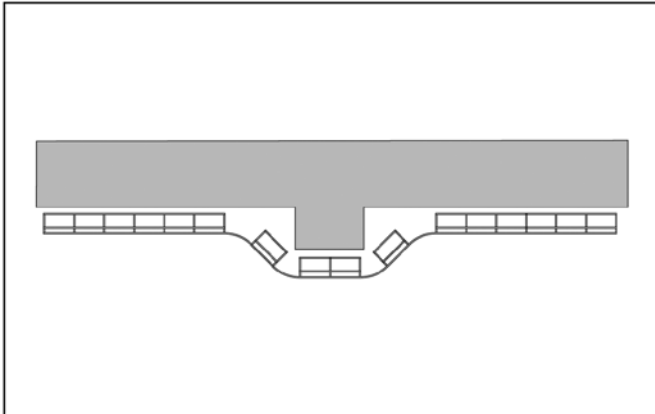

Any level difference can be obtained by cutting away the corresponding zone and bending the cable basket at that spot, until the required shape has been reached.
For extra reinforcement, the use of the connection plate V35.200 is being recommended.

Cutting and bending

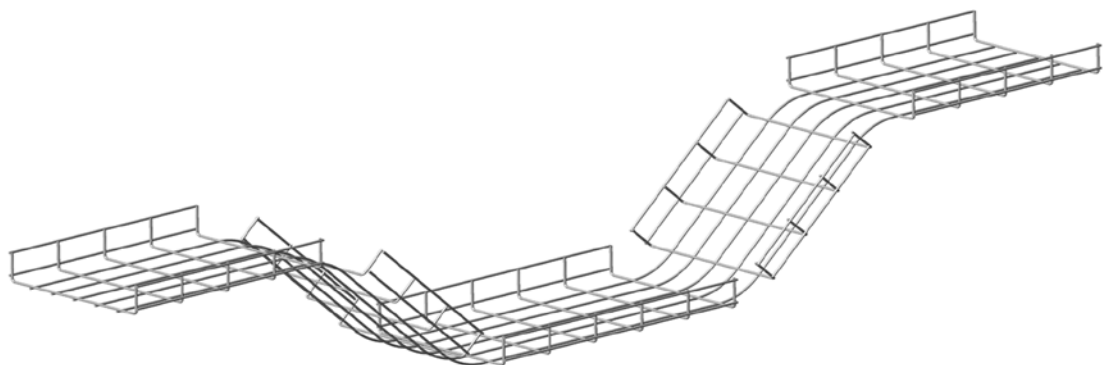
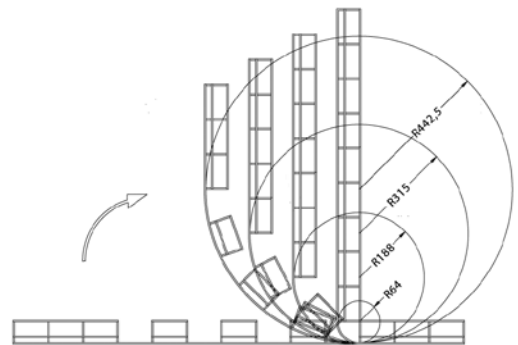
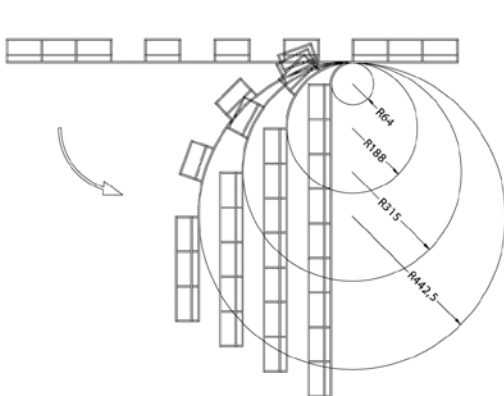

REDUCER

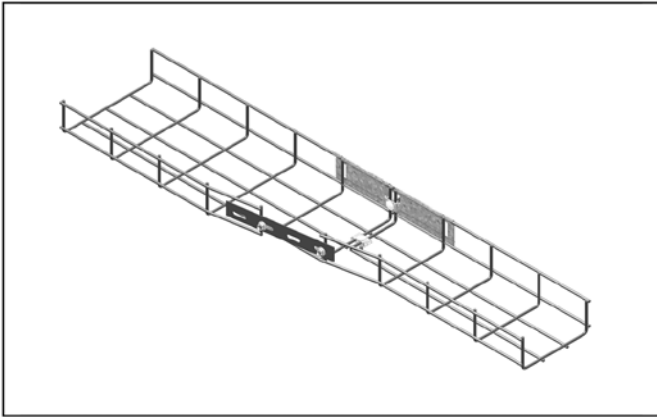

Cable basket can be reduced in order to connect them to a smaller section. All combinations are being based upon a few basic principles in order to obtain the required result.

1. Cut away the required zones from the bottom and the side.
2. Bend the side to the required width.
3. Connect the ends by means of KPVF, VFK and V35.200

Difference of 50mm

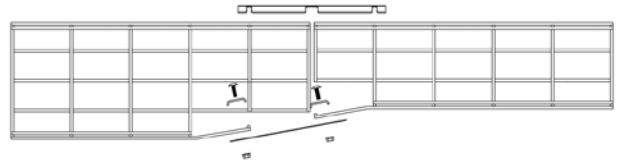
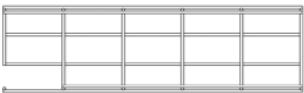
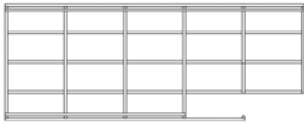

Difference of 100mm

